

F260.160 max pull 160 kN

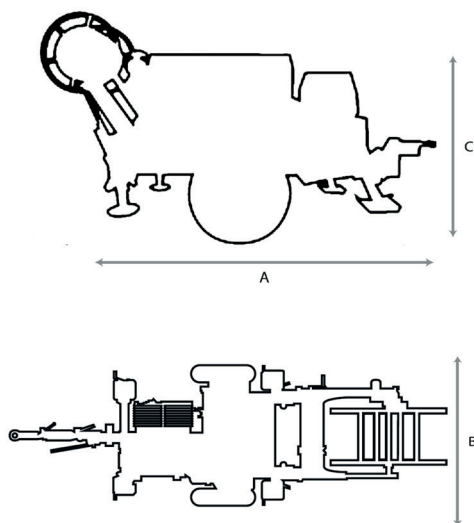

Hydraulic puller fit to pull one rope in stringing operations of overhead transmission lines. One hydraulic circuit allows to continuously vary the speed in both directions by operating one control device.

- One pair of multi-grooved steel capstans fit for stringing one steel rope.
- Machine control panel equipped with built-in electronic instrument featuring a large graphic color display and a USB port. Main functions include display of pull-force, speed and length of cable in real time, max pull force setting, display of working hours, data recording and storage on a pen-drive (data processing software provided).
- Device for pull force setting which allows to maintain the pre-set force even at speed "0".
- Safety negative hydraulic brake.
- Chassis with rigid axle, manual brake and detachable drawbar for towing at low speed in job-site.
- Hydraulic back stabilisers and manual front stabilisers.
- Attachments for anchoring and for lifting.
- Heat exchanger to cool the oil in the hydraulic circuit.
- Reelwinder fit for a 1600-mm-dia reel, with automatic ropewinder.

OPTIONAL DEVICES

- 008 Axle with leaf spring suspensions, drawbar, pneumatic braking system, tires and lights for towing on the road (without homologation).
- 006.1 Lights for towing on the road.
- 006.2 Pneumatic braking system.
- 028.7 Device to start the diesel engine and the hydraulic circuit at low temperatures (up to -30°C).
- 037 Remote control by cable, with 10 m of cable.
- 038 Radio-control (max distance 50 m).
- 045.2 Automatic clamp for rope.
- 045.3 Manual clamp for rope.
- 047 Hydraulic front stabilisers.
- 069.5 Printer with accessories, complete with case.
- 084 Bigger reelwinder fit for a 1900-mm-dia reel.
- 115 Setting-up for pulling 2 ropes simultaneously.
- 014 Second reel-winder, ideal to complete the opt. 115.
- 174.1 Synchroniser device for matching 2 machines to pull 2 ropes simultaneously, complete with remote control by cable(20 m) for controlling the 2 machines.

FEATURES

Capstans	2 x Ø 600 mm
Grooves on the capstans	10 + 10
Max rope diameter	24 mm
Max joint diameter	60 mm
Dimensions AxBxC	4,10x2,42x2,30 m
Weight (without rope)	5200 kg

ENGINE

Feeding	diesel
Power	290 hp / 215 kW
Cooling	water
Electric plant	24 V

PULL PERFORMANCES

Max pull	160 kN
Speed at max pull	2,5 km/h
Max speed	5 km/h
Pull at max speed	80 kN

ALSO AVAILABLE F260.190

max pull force	190 kN
speed at max force	2,2 km/h
max speed	5 km/h
pull at max speed	80 kN